

# HIPERTOUC<sup>®</sup> Auto

NFA Rules Apply, Parts/Installation Manual

Proper installation and use of this product are the responsibility of the purchaser. It is highly recommended that the purchaser have the product installed by a commercially engaged gunsmith.



2 User-Adjustable Semi-Auto Trigger Weights: 2½+, 3½+ lbs. Single Stage Pull Is Smooth, Flat, Fast & Precise. MIL Pre-Travel w/ Positive Reset. Hammer Fall: Heavy, Like Stock for More Reliable Cartridge Ignition. Soft-Start™ Lock-Up. 0.154" Diameter MIL-Spec Pivot Pins. Installs w/o Removal Of Safety Selector. No Mods or Adjustments Req'd. US Patents: 8572880, 9175917, 9696103, D817436, 10006733, 10222161. Others Pending. Made in the USA.

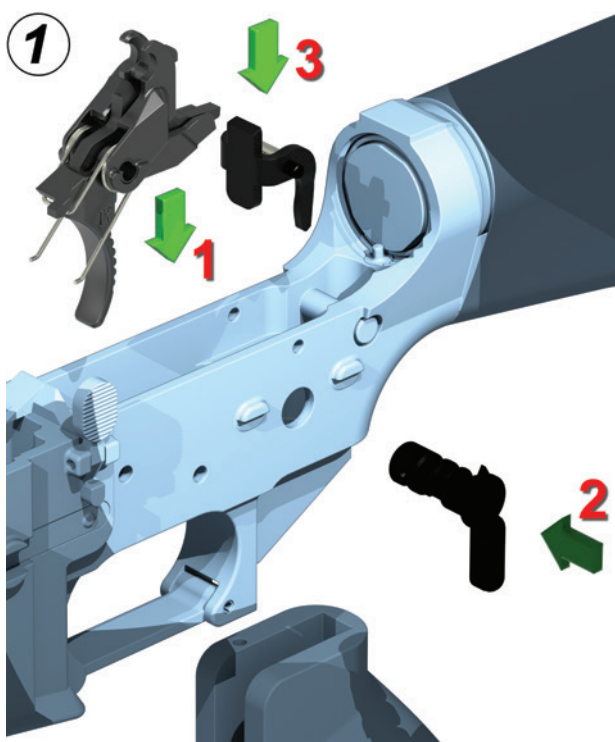

Remove the safety, the grip, and the auto sear. **The trigger subassembly comes preassembled as shown w/ sleeve, etc.** First, view the installation videos at [hiperfire.com](http://hiperfire.com) to see how the trigger system is assembled and how the parts interact. **NEXT, WEAR EYE PROTECTION.** Align the trigger sleeve so that its notch openings align with the frame's notches so the hammer spring's arms can nest to retain the trigger pivot pin. If this is out of alignment the pivot pin could work its way out. Insert the trigger group as shown into the M4/M16 lower receiver as per Diagram 1. Reinstall the safety, grip, and auto sear.

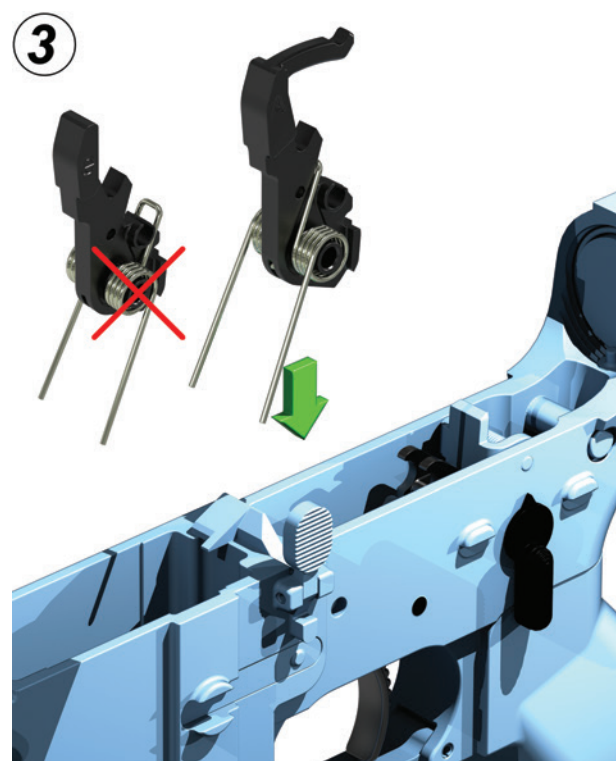

The hammer is shown with the custom hammer spring installed. If it needs replacement, remove it and install a new hammer spring like you would for a stock AR15 or M4/M16 hammer. Insert the hammer into the lower receiver in the usual way (just like you would a stock AR15 or M4/M16 hammer), making sure the hammer spring's arms nest in the spaces on either side of the trigger subassembly's frame and the lower receiver (the hammer spring arms retain the trigger pivot pin you installed in the previous step). Also shown, is an incorrectly installed hammer spring.

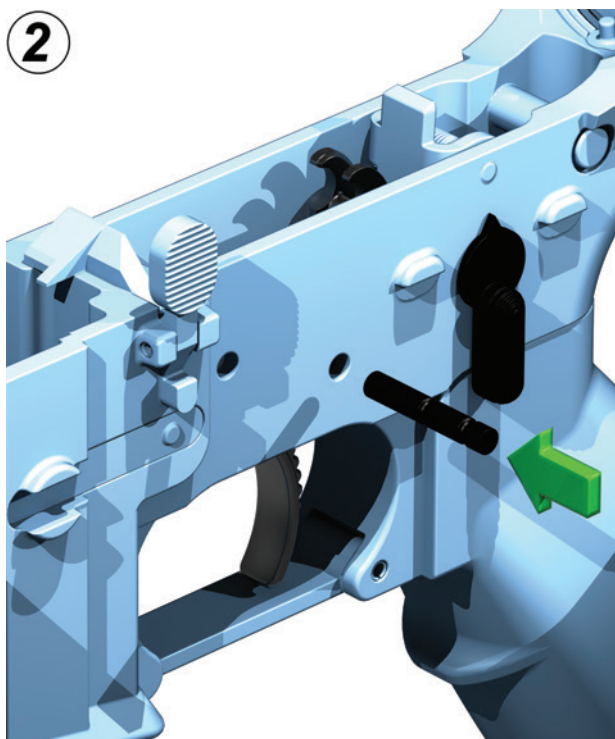

To complete installation of the trigger subassembly, insert the stock receiver 0.154-inch diameter pivot pin in the usual way (just like you would install a stock AR15 or M4/M16 trigger). Install the trigger shoe during trigger insertion, or after, as shown.

**IMPORTANT** - Install only the trigger springs that are supplied with the fire-control. Altering these springs not only voids the warranty, but may change trigger pull significantly, changing your pull effort and/or timing with unexpected results. **Replace worn out or damaged trigger springs with new replacements.**

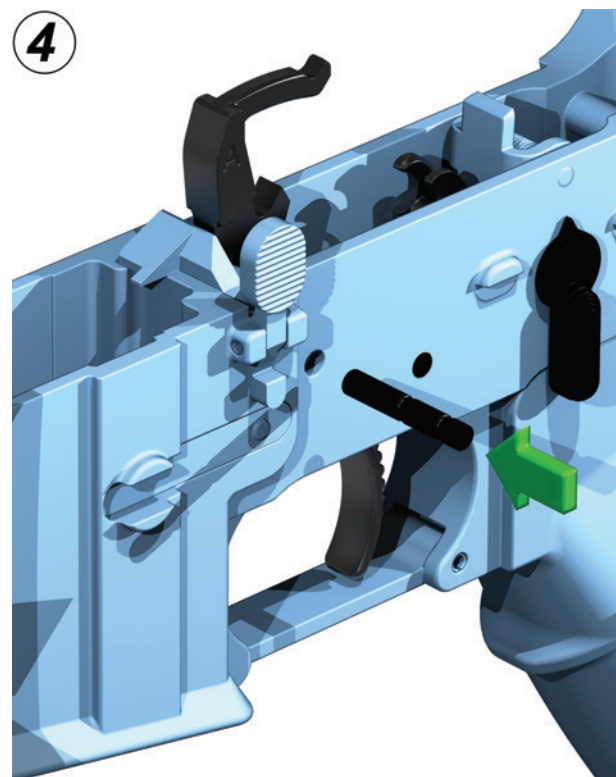

Complete installation of the hammer subassembly by inserting the stock M4/M16 0.154-inch diameter pivot pin like you'd install a stock AR15 or M4/M16 hammer.

**IMPORTANT** - All AR15 or M4/M16 hammer springs may relax over time, especially if the rifle is stored for long periods of time with the hammer cocked. If relaxation occurs, a cartridge may not fire when the hammer falls. Replace the spring as necessary.



1. (1) FULL-AUTO FRAME
2. (1) FULL-AUTO TRIGGER
3. (1) TRIGGER SLEEVE
4. (1) FULL-AUTO HAMMER
5. (1) FULL-AUTO DISCONNECTOR
6. (1) TOGGLE YOKE
7. (1) TOGGLE PIVOT
8. (1) GREEN HAMMER SPRING
9. (2) RED TOGGLE SPRINGS for MEDIUM-LIGHT TRIGGER PULL WEIGHT
10. (2) GREEN TOGGLE SPRINGS for LIGHT TRIGGER PULL WEIGHT
11. (2) 0.154" DIA. PIVOT PIN
12. (1) DISCONNECTOR SPRING
13. (1) TRIGGER SPRING

HIPERTOUC<sup>®</sup> Auto fire-control group (FCG) parts are shown in the figure by name and quantity. **The trigger portion comes preassembled w/ TRIGGER SLEEVE, etc.** It "drops" in complete; just pin in place.

**IMPORTANT** - Note well the correct installation orientation of the hammer spring on the hammer. **It is possible to install it backwards. The result would be very light trigger pull weight and light hammer strikes (poor or no ignition).**

**5** Rotate the toggle yoke until the middle D-shaped pivot portion will drop into the hammer's pivot notch (see the cross-section of Figure 5 below). Once in place, the yoke can rotate freely without becoming disengaged over its operational rotation range. Once the toggle yoke is in position, place a matched pair of toggle springs over the ends of the yoke arms. By way of example the GREEN springs shown provide a pull weight of approximately 2½ lbs.

**IMPORTANT** - It's possible that over time the spring's color coding could come off or be obscured by oil and grime, etc. If the color coding comes off, the easiest way to identify an identical pair of springs is to count the number of coils. Identical springs will have the identical numbers of coils. Or, measure the wire diameter. Identical springs will have the same wire diameter. Furthermore, installation of springs with the fewest coils and largest wire diameter will result in the lowest trigger weight. Conversely, the highest pull weight corresponds to the highest coil count and smallest wire. If an installation toggle spring pair is not matched, the spring force will not be balanced and the hammer may not pivot smoothly, especially if the fire-control is not maintained by regular cleaning and lubrication. Consequently, the semi-auto trigger pull weights of ~2½ or ~3½ lbs. will be markedly different. **Make sure the toggle spring pair is matched.**

**WEAR EYE PROTECTION.** Apply toggle pivot as shown and compress the parts using a tool inserted into the pivot's pocket hole, shown by the arrow, against the stationary hammer.

**IMPORTANT** - Do not install toggle spring pairs other than those provided with the HIPERTOUCHE® fire-control. Installation of other springs not only would void the warranty, but could also be hazardous under the right conditions. If you lose a spring, contact HIPERFIRE for replacement.

**IMPORTANT** - Toggle springs must be installed for proper and safe function of the fire-control. If they are not installed, the frame could rotate and obstruct proper functional rotation of the disconnecter. If this were to occur, it may not be heard at first (if at all) when the action cycles, or when the trigger is pulled to cause hammer fall. Later, the hammer, trigger, and disconnecter could be damaged causing unpredictable firing events that could be hazardous.

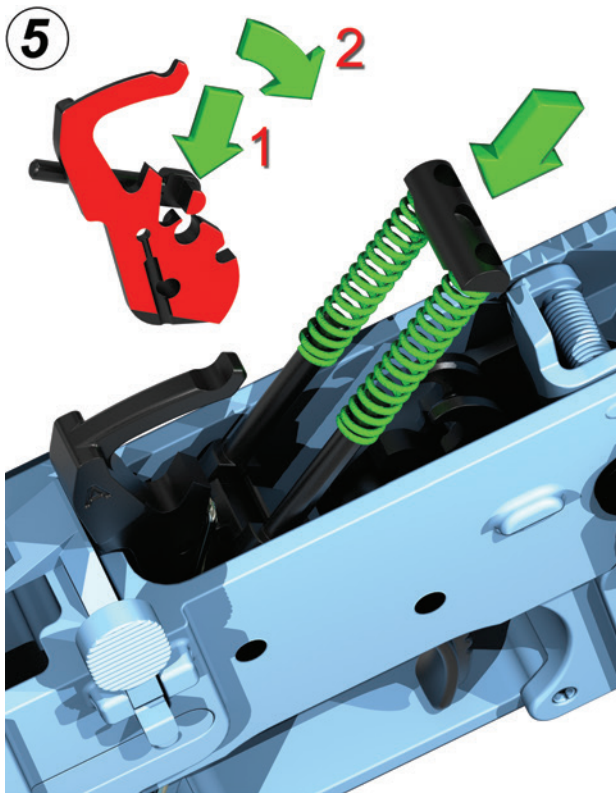

**Inspect the fire-control for proper toggle spring installation and function whenever live-fire exercise is intended, especially if you had the fire-control installed by someone else, or if you loaned your rifle to someone else.**

Of course, this is standard safety practice with any firearm. Make safety your first priority.

**6** Secure the lower receiver to facilitate compression of the toggle spring assembly. Rotate the subassembly down (about the toggle yoke's pivot) so that the toggle pivot can engage and snap into the frame's pivot notch. Insertion can be done without tools; extraction will require them. Test the fire-control for proper function before attaching the upper receiver.

**IMPORTANT** - Testing procedure: manually cock the exposed hammer with your finger off the trigger. Pull the trigger to cause hammer fall onto something safe, like a hammer fall block made for that purpose. The hammer should strike very fast with noticeable energy. Then recock the hammer, etc., and repeat the procedure as necessary for your examination. The hammer "feel" during cocking should be very smooth, with no tactile feedback grittiness, or indication of obstruction. You should hear nothing but the trigger engaging the hammer sear with an audible "click." If you hear anything but this, there might be something wrong. Check for parts that are out of alignment, not seated in notches, not parallel, etc. If it sounds and looks okay, next, before cocking the hammer, pull the trigger to the rear and fully seat it against the safety/selector. Now, cock the hammer slowly and smoothly. You should see and hear the semi-auto disconnecter pivot and "click" as the hammer's disconnecter sear snaps through the disconnecter's sear causing the disconnecter to pivot and return very quickly. Continue cocking the hammer by pressing it down until it stops and then slowly release it. Now, ease off the trigger; the hammer should pop up and stop in a cocked position with an audible "click." Now, pull the trigger as before and repeat the latter process several times until you are satisfied that it's smooth and quiet (excepting of course, the mechanism's "clicks"). If all of the this happens without any grittiness in the trigger and hammer, the trigger resets quickly and surely, the hammer release by the semi-auto disconnecter is quick and sure, hammer fall is very fast, etc., then the installation is probably successful. The HIPERTOUCHE® fire-control's sear engagement functionality is the same as that of stock AR components. If the HIPERTOUCHE® operates like a stock installation with the same smooth motions and sounds, then the installation is successful. **Continue dry-fire testing of the fire-control after attaching an unloaded upper receiver to practice safe operation, while accustoming your grip and trigger stroke to the new trigger pull weight.**

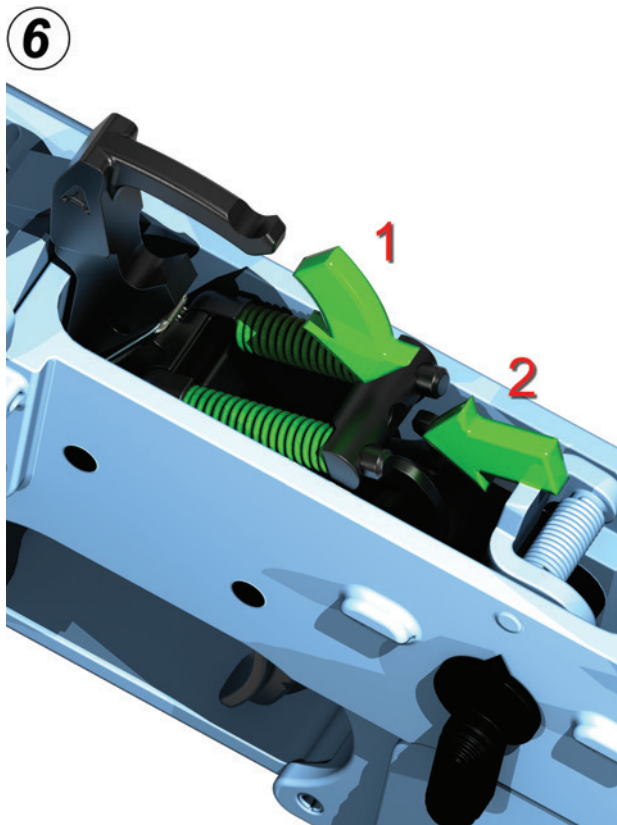

Reverse the steps to uninstall the parts and reinstall with a different spring combination to change trigger pull according to the table. Use a pointed tool inserted into the toggle pivot at the arrow for convenient removal and reinsertion.

## NOTICE

HIGH PERFORMANCE FIREARMS LLC specifically disclaims responsibility for any damage or injury whatsoever occurring in connection with, or as the result of the installation, use, or misuse of a HIPERTOUCHE® product in AR15/AR10 pattern firearms that are in good or worn condition, that are nonstandard, or have been modified.

## CRITICAL Safety Warnings

A firearm and its fire-control are a system and must work together. There are different types of fire-controls for different types of firearms. Your firearm has been designed for a fire-control of a specific type. It is important to select the proper fire-control for your firearms.

Receive competent instruction in firearm safety. Practice with an unloaded firearm, or with dummy ammo, until you are completely familiar and comfortable with firearm safety procedures. Use live ammunition only when you are prepared to shoot safely.

Death, serious injury, and damage can result from the use of misuse of any fire-control in any firearm.

Keep the muzzle of any firearm pointed in a safe direction and follow all safety procedures at all times.

Do not drop your firearm. Always follow safe firearm handling practices when moving from one shooting position to another, or when transporting it (whether cased or not).

AR15 and AR10 type firearms employ safeties, but do not rely on them exclusively for safety.

Never pull the trigger unless the safety is set to FIRE and you intend to shoot.

Keep the firearm chamber empty unless ready to shoot and maintain safe muzzle direction.

Know your target and what is behind or beyond it.

Never perform maintenance on a loaded firearm.

Do not modify the firearm or the fire-control parts.



The HIPERTOUCHE trigger product is warranted against original defects in materials and/or workmanship for the life of the product from the date of purchase. The warranty is VOID if the product has been modified. This warranty applies to the original purchaser and is not transferable. This warranty applies only to purchases made in the United States of America.

HIPERFIRE will replace the product (subject to availability) if defective under warranty. Go to [HIPERFIRE.com/Support](http://HIPERFIRE.com/Support) for instruction on how to submit a warranty claim. Please keep your purchase receipt and provide an explanation of the defect.

HIPERFIRE shall not be liable for any consequential, incidental, or contingent damages whatsoever. Some states do not allow the exclusion of incidental or consequential damages, so the above limitation or exclusion may not apply to the original purchaser. This warranty gives the original purchaser specific legal rights, and the original purchaser may have other rights, which vary from state to state.